

Railing Against the Elements

With careful detailing and proper flashing, exterior woodwork should last for decades

by Scott McBride



Mushrooming problems. When fungi sprout from railings, it's a rotten sign. Pictured here is a close-up of the railing the author was hired to replace.

The moist climate of New York's Hudson Valley isn't exactly ideal for carpenters like myself. We have muggy summers, slushy winters and three months of rain in between. As we struggle through weeks of unremitting precipitation with fogged-up levels and wet chalk lines, there is but one consolation: come April, a billion fungal spores will bloom, reaching into every water-logged mudsill, fascia and doorstep. That means a guaranteed crop of rot-repair jobs in the coming season.

Of all the woodwork exposed to the elements, none is so vulnerable as the white pine porch railing. With the right combination of faulty detailing and wind-driven rain, a railing can be reduced to shredded wheat in about eight years. I typically rebuild several of these railings each year. In this article I'll describe one such project (photo facing page).

Getting organized—A railing around the flat roof of a garage had rotted out (photo above), and the owner asked me to build a new one. This wasn't a deck that was used, so the railing was decorative rather than functional, and one of my worries was installing the new railing without making the roof leak (more about

that later). On a house across town, my customer had spotted a railing that he liked and asked if I could reproduce it. I said I could and took down the address.

Before leaving the job site, I made a list of the rail sections I would be replacing, their lengths and the number of posts I would need. Later that afternoon I found the house with the railing my customer liked, strolled up the walk and began jotting down measurements. The family dog objected strenuously to my presence, but no one called the police.

Back at the shop I drew a full-scale section of the railing and a partial elevation showing the repeating elements. The next bit of work was to make layout sticks (or rods) showing the baluster spacing for the different rail sections (see the sidebar on p. 70). This would tell me the exact number of partial- and full-length balusters that I would need.

The right wood—I'm fortunate to have a good supplier who specializes in boat lumber. He carries premium grades of redwood, cedar, cypress and Honduras mahogany, all of which resist decay well. I used cypress for the rails and balusters because it's less expensive and

because the rough stock is a little thicker than the others. Cypress is mostly flatsawn from small trees, though, and the grain tends to lift if the wood isn't painted immediately.

Much of the Western red cedar at this yard is vertical grain—the annual rings run perpendicular to the face—and hence inherently stable. I typically use it for wider pieces where cupping could be a problem. Square caps on posts fit this description because they are so short in length. They should always be made from vertical-grain material or they'll curl in the sun like potato chips.

For this job I bought 2-in. thick cypress for the rails and balusters, 5/4 red cedar for the rail caps and post caps, and 1-in. cedar boards for the box newel posts,

Bevels and birds' mouths—After cutting the lumber into rough lengths with a circular saw, I jointed, ripped and thickness-planed the pieces to finish dimensions. Using a table saw, I beveled the top, middle and bottom rail caps at 15° (drawing facing page). Besides looking nice, the bevels keep water from sitting on what would otherwise be level surfaces.

I had to cut a bird's mouth on the bottom of

Railing anatomy



Box newel post is composed of four 1-in. thick cedar boards biscuit-joined and glued together, all of which slips over a pressure-treated 4x4.

1/4-in. air space between base and deck

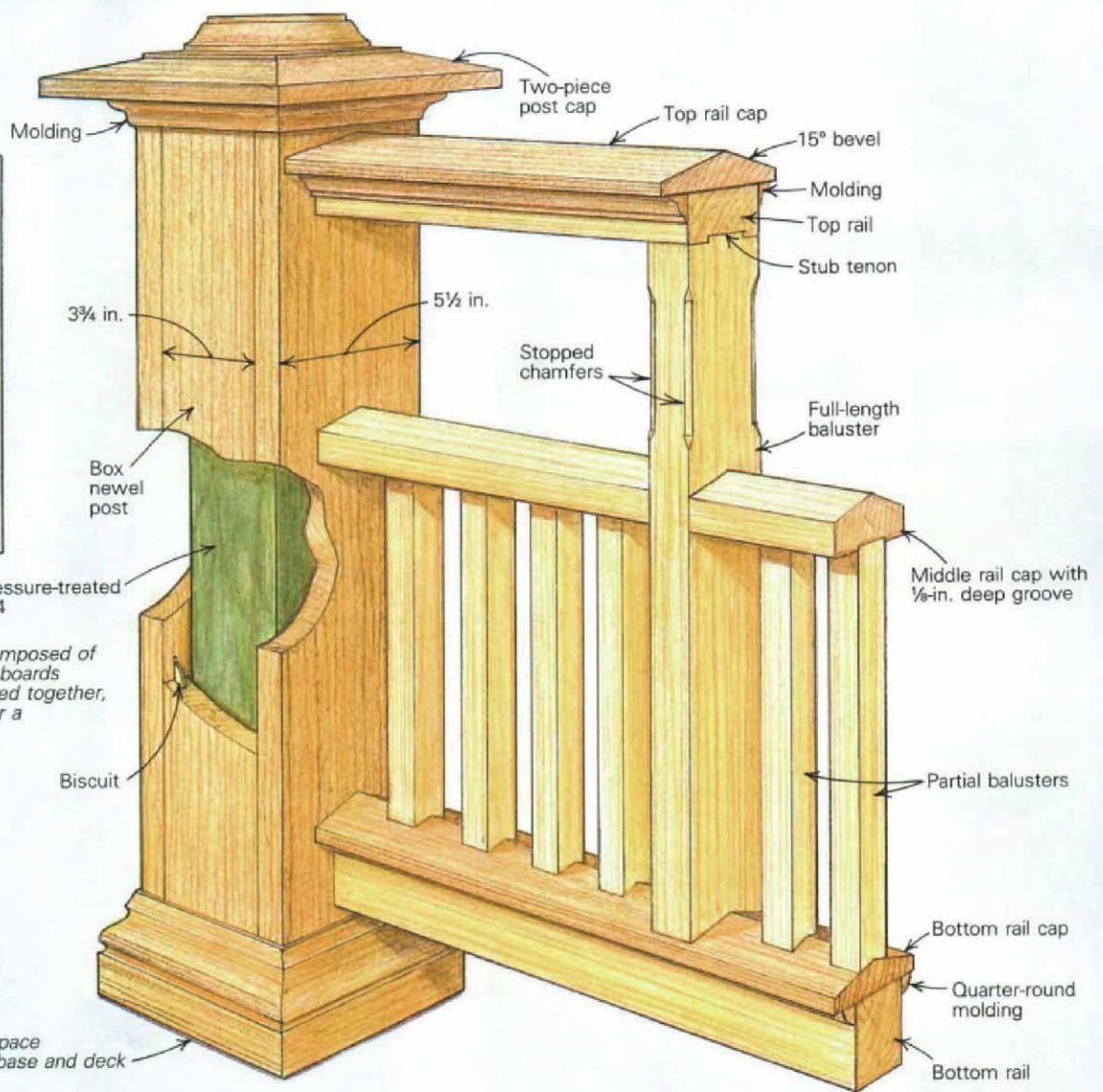

each partial baluster so that the baluster would fit over the beveled cap on the bottom rail. Rather than make each bird's mouth individually, I first crosscut my 2x6 baluster stock to finished length and jointed one edge. I then ripped just enough off the opposite edge to make it parallel to the jointed edge. With the blade on my radial-arm saw raised off the table and tilted 15°, I made an angled crosscut halfway through the thickness of the baluster stock. Flipping the piece, I made the same cut from the opposite face. Individual balusters were then ripped from the 2x6, with each bird's mouth already formed.

I used the same setup to cut birds' mouths in the full-length balusters, but cut them one at a time because they were wider. These uprights also have decorative stopped-chamfers routed into them. The chamfer bounces light smack into your eye in a most appealing way.

Next I set up the dado cutterhead on my table saw. I ploughed a shallow groove for the partial balusters in the underside of the middle rail, and another to receive the full-length balusters in the underside of the top rail. Although these grooves are a mere 1/8 in. deep, they made assembling the railing much easier

Decorative railings. The original railing around the deck over the garage rotted out prematurely, so the owner of the house commissioned a new railing of a slightly different design—one copied from a house across town. Carefully detailed of cypress and cedar, the new railing should last a long time. *Photo by Kevin Ireton.*



and ensured positive alignment of the vertical members. The tops of the partial balusters are housed completely in the groove, but the tops of the full-length balusters also have stub-tenons, cut on the radial-arm saw.

Box newel posts—Each box newel post is a two-part affair. I cut rough posts from pressure-treated yellow pine 4x4s and outfitted them with soldered-copper base flashing (top drawing, next page). This flashing would later be heat-welded to the new roof surface (more on that in a minute). A finished cedar box newel post would slip over the rough post and receive the railings.

Because the sides of the box newels were to be butt-joined, two sides were left their full 5 1/2-in. width, and the other two were ripped down to 3 3/4 in. so that the finished post would be square in cross section. I saved the ripplings to make the quarter-round molding that's under the bottom rail cap.

The box newels were glued up with a generous helping of resorcinol to keep out moisture. Glue also does a better job of keeping the corner joints from opening up than nails do. To align the sides of the box newels dur-

Flashing a post base

Copper flashing was used around the bases of the 4x4 posts that anchor the railing. The necessary shapes were initially worked out in paper patterns, then cut out of 14-oz. copper.

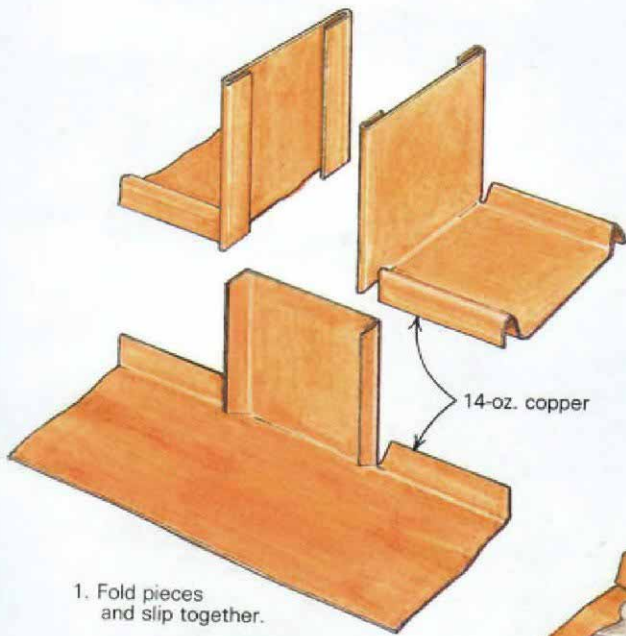

1. Fold pieces and slip together.

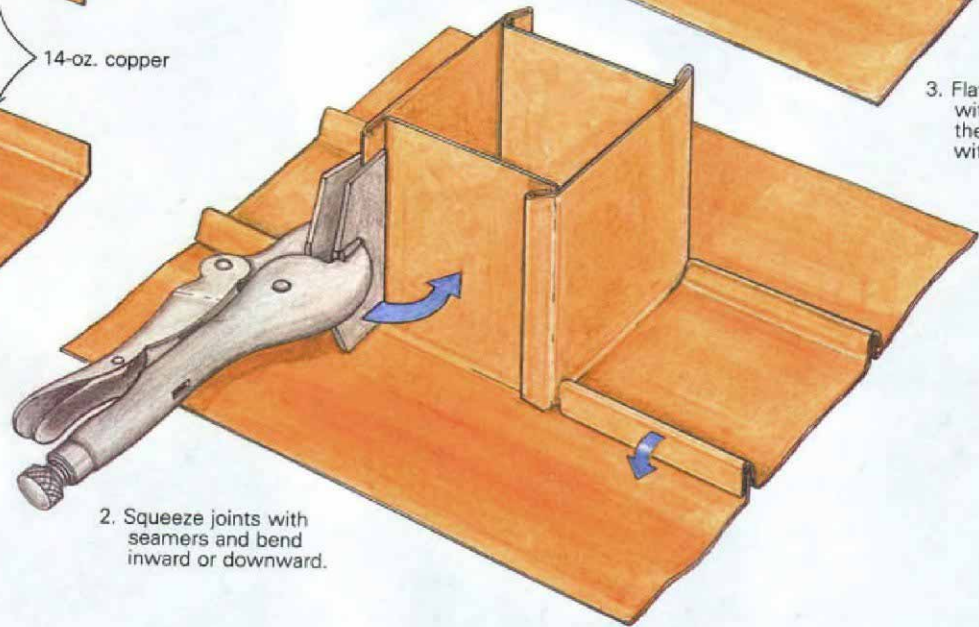

2. Squeeze joints with seamers and bend inward or downward.

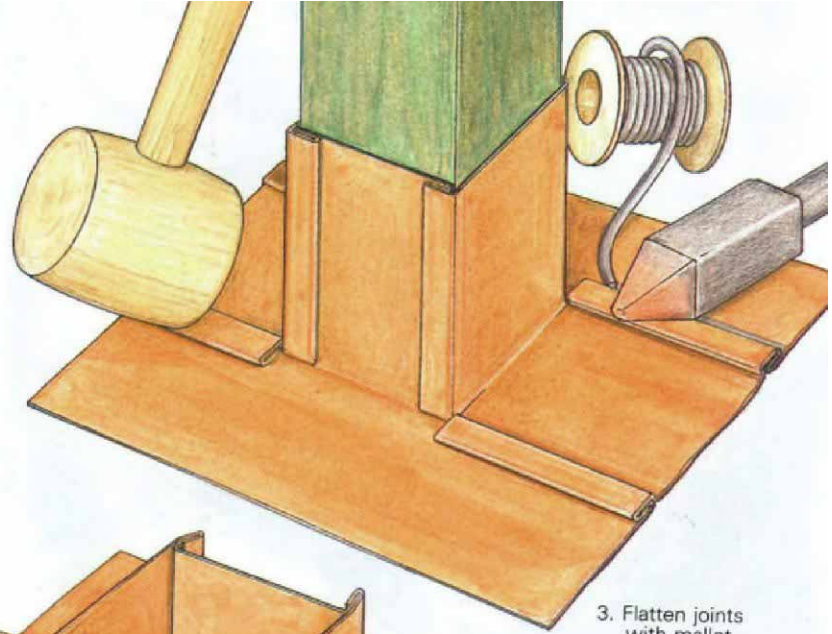

3. Flatten joints with mallet, then seal them with solder.

Spacing balusters

Spacing balusters correctly is a simple trick, but it's surprising how many carpenters are stumped by it. The object is to have equal spaces between each baluster and between balusters and posts.

Suppose your railing is $71\frac{1}{8}$ in. long., your balusters are $1\frac{1}{2}$ in. square, and you want a spacing of 4 in. o. c.—that is, $1\frac{1}{2}$ in. of wood, $2\frac{1}{2}$ in. of air, $1\frac{1}{2}$ in. of wood, and so on.

Begin the layout from the post on the left, by tentatively laying off a $2\frac{1}{2}$ -in. space ending at point A in the drawing below. From there you stretch a tape and see how close you come to the post on the right with a multiple of 4 in. In this case 68 in. (a multiple of 4) brings us to point B, which is $1\frac{1}{8}$ in. from the right-hand post. Forget about this remainder for the moment.

Dividing 68 by 4 tells you that you will have 17 intervals containing one baluster and one space, plus the extra space you laid out at the

start. That makes 17 balusters and 18 spaces. Now you're going to lay out the combined dimensions of all 17 balusters ($17 \times 1\frac{1}{2}$ in. = $25\frac{1}{2}$ in.) from the left-hand post. That brings you to point C. From there you're going to lay off the combined dimensions of all the spaces, bringing you to point B—close, but not close enough. To land directly at the post, divide the remaining $1\frac{1}{8}$ in. by 18 (the number of spaces) and add the quotient to each space. How fortunate $1\frac{1}{8} \div 18 = \frac{1}{16}$. That gives you a nice, neat adjusted dimension for the space of $2\frac{9}{16}$ in.

If the numbers don't divide evenly, I'll use a pair of spring dividers to find the exact space dimension by trial and error, stepping off the distance from Point C to the post. When I find the right setting, I lay off the first space. Then I add this dimension to the baluster width, reset the spring dividers to the sum distance, and step off the actual spacing. This method avoids the accumulated error that happens when using a ruler and pencil, not to mention all that excruciating arithmetic. —S. M.

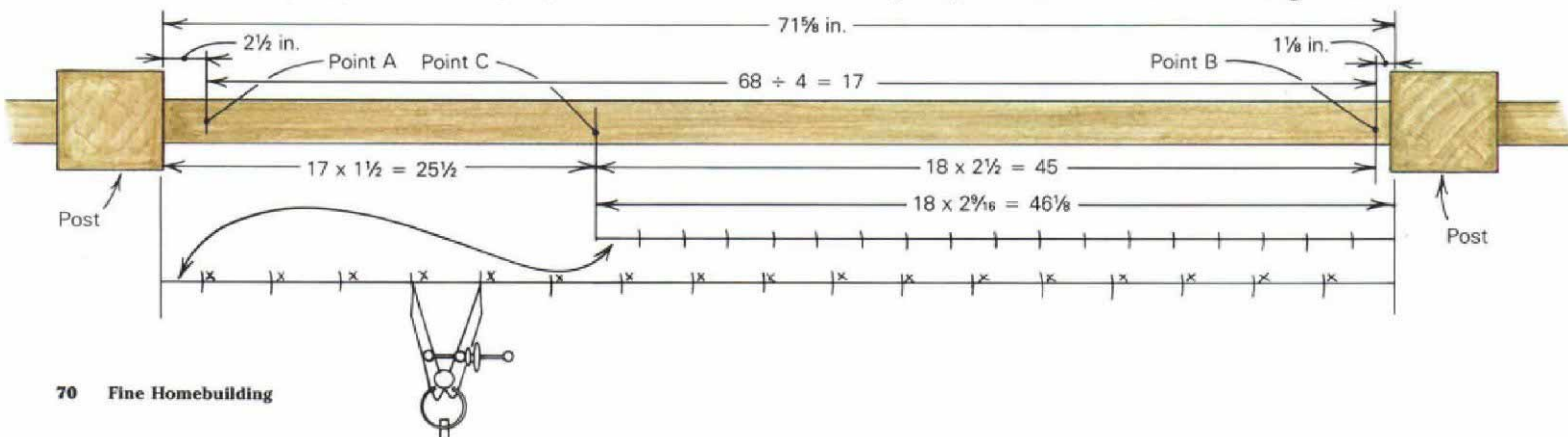

ing glue-up, I used three biscuit joints along the length of each side.

The last parts to be fabricated were the post caps. The square lower part of the cap is a shallow truncated pyramid, produced by making four consecutive bevel cuts on a table saw. I made the round upper part on a shaper. The two parts were glued together with the grain of each parallel to the other, so they would expand and contract in unison.

To reduce the amount of water running down the face of the post, I cut a drip groove around the underside of the cap with a 1/8-in. veiner bit mounted in a router table. Using the same bit, I also routed a series of ventilation grooves into the underside of the cap in a tic-tac-toe pattern (detail drawing, p. 69). They allow air taken in at the bottom between the rough post and the box newels to escape at the top without letting in rain.

Assembling the rail sections—I assembled the rail sections in the shop where I could count on dry weather and warm temperatures. The first step was to face-nail the bottom rail cap to the bottom rail. I placed the nails so that they would be covered subsequently by the ends of the balusters.

I toenailed the balusters in place with 4d galvanized finish nails. This was easy to do because the bevel and bird's-mouth joinery prevented the balusters from skidding around as I drove the nails.

The middle rail was cut into segments to fit between the full-length balusters. I took the lengths of the segments, along with the spacing for the partial balusters, directly from the layout on the bottom rail cap. Every other segment of the middle rail could be attached with 3-in. galvanized screws through the uprights. The intervening segments were toenailed with 8d galvanized finish nails. Then I face-nailed through the middle rail down onto the tops of the partial balusters. The top rail was screwed down onto the full-length balusters. I left the top-rail cap loose so that it could be trimmed on site for a tight fit between the newels.

Still in the shop, I caulked all the components with a paintable silicone caulk, primed the wood and then painted it with a good-quality latex house paint. With a truckload of completed rail sections and posts I headed for the job site with my crew.

Installation—My roofing contractor had replaced the existing 90-lb. rolled roof over the garage with a single-ply modified-bitumen roof. One advantage of modified bitumen is that repairs and alterations can be heat-welded into the membrane long after the initial installation. This meant I didn't have to coordinate my schedule with that of the roofer to fuse the copper base flashings to the new roof. Flashing strips of the bitumen were melted on top of the copper flange (photo right), providing two layers of protection (including the copper) around the base of the post and a "through-flashed" layer of roofing beneath the post.

The railing is U-shaped in plan, and I an-



Fused flashings. One of the advantages of a single-ply modified-bitumen roof is that repairs and alterations can be heat-welded to the membrane long after the initial installation. Here, flashing strips of bitumen, which cover the copper base flashings around the 4x4 posts, are being fused to the roof membrane.

chored the two ends into the house. However, I didn't want to penetrate the roof membrane with framing or fasteners, so the newel posts are only attached to the deck by way of their flashings. Although this method of attaching the posts provides superb weather protection, the intermediate posts are a bit wobbly. This was okay for this particular deck because the railing is strictly decorative. Where a roof deck is subject to heavy use, the posts should be securely anchored to the framing.

With the rough posts in place, installation of the railing was straightforward. Box newels were slipped over the 4x4s and roughly plumbed. We stretched a line between corner newels and shimmed the intermediate newels up to the line. All box newels were held up off

the deck at least 1/4 in. to allow ventilation. The difference between the rough post dimension (3 1/2 in. by 3 1/2 in.) and the internal dimension of the box newels (3 3/4 in. by 3 3/4 in.) allowed for some adjustment. When the newels were just where we wanted them, we simply nailed through the shims and into the rough posts.

In some cases rail sections had to be trimmed. When the fit was good, top, middle and bottom rails were snugged up to the posts with galvanized screws. All that remained was to glue cypress plugs into the counterbored holes and shave them flush. □

Scott McBride is a builder in Sperryville, Va., and a contributing editor of Fine Homebuilding. Photos by author except where noted.